



Float Switches

“20A100-E” Series Navigator Plus Float Switches

Features & Benefits

- Durable ABS Body Foam Filled Construction
- Mechanical Type Actuation (No Mercury)
- Wide Angle (90° Operating Range)
- Pump Duty Rated
- Rated 1 Hp @ 120VAC, 2 Hp @ 240VAC (15 Amps)
- Available with Piggyback 120V or 230V Plug or without Plug
- Available in Pump Up or Pump Down Configurations
- Available w/External Weight, SST Pipe Clamp or Cable Tie
- Multiple Cord Lengths Available

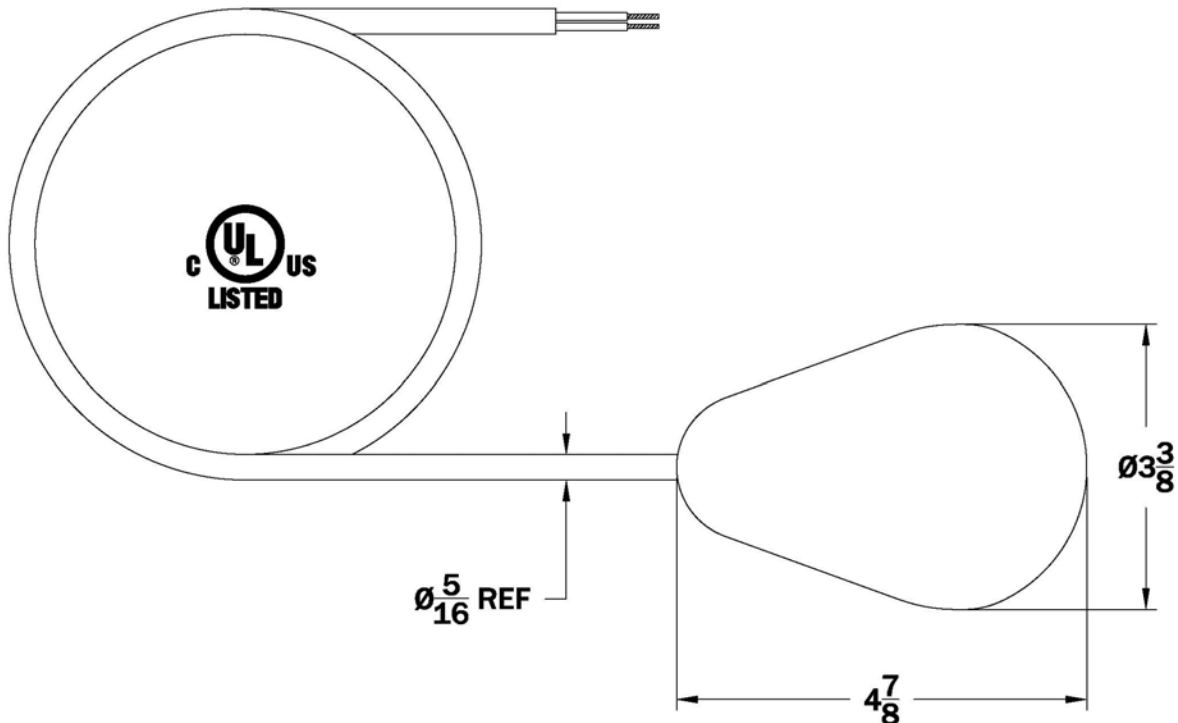

*Note: Consult the factory for other available options.

“20A100-E” Series Navigator Plus Float Switches

Typical Mounting

