



## Float Switches

### “20A300” Series A-Navigator Float Switches

#### Features & Benefits

- Durable ABS Body Construction
- Mechanical Type Actuation (No Mercury)
- Wide Angle (90° Operating Range)
- Pump Duty Rated
- Rated 1½ Hp @ 120VAC, 3 Hp @ 240VAC (25 Amps)
- Available in Pump Down Configurations
- Available w/External Weight, SST Pipe Clamp or Cable Tie
- Multiple Cord Lengths Available
- Foam filled for durability

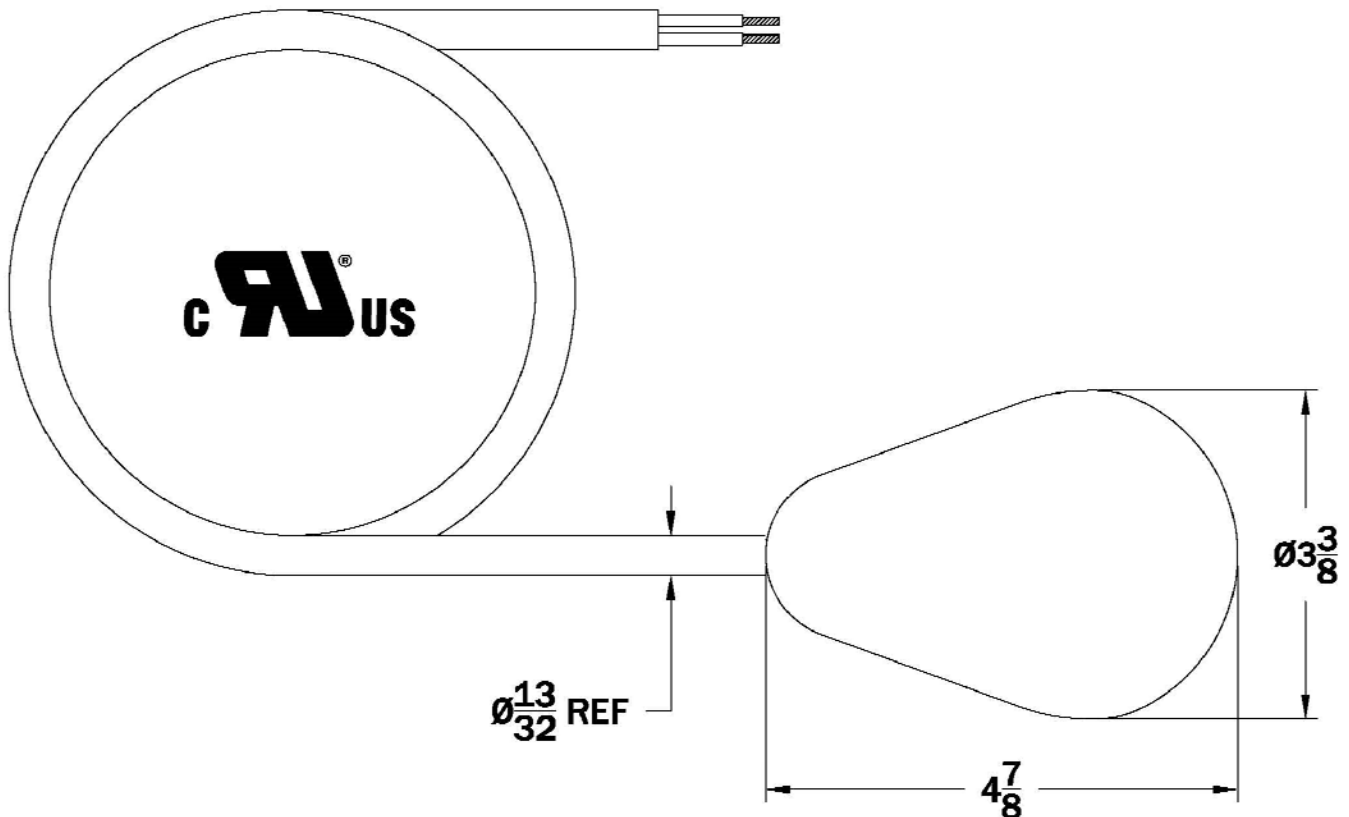

\*Note: Consult the factory for other available options.



**Float Switches**

**“20A300” Series A-Navigator Float Switches**

**Typical Mounting**

