

“50B109-CAV” Model Aerobic Control Panel

Features & Benefits

- **Circuit Breakers for Pump, Compressor & Alarm Circuits**
- **24 Hr Timer w/15 minute intervals**
- **Large & Easy to Access Terminal Block**
- **Externally Mounted Run/Mute/Test Switch w/UV resistant sealing boot**
- **Externally Mounted Audible Alarm**
- **Rugged UV resistant Externally Mounted Alarm Light**
- **Durable Weather Resistant Hinged Poly Enclosure**
- **Silk Screen Back Panel**
- **Ground Lug**
- **Easily Replaceable Components**
- **Nema 4x Rating**
- **Built and Labeled to UL 508A Standard**
- **Works with most Aerobic Treatment Systems**
- **Provided with Wiring Schematic and Detailed Connection Diagram for Installer**
- **Mounting Feet for Enclosure**
- **Two year limited control panel warranty**

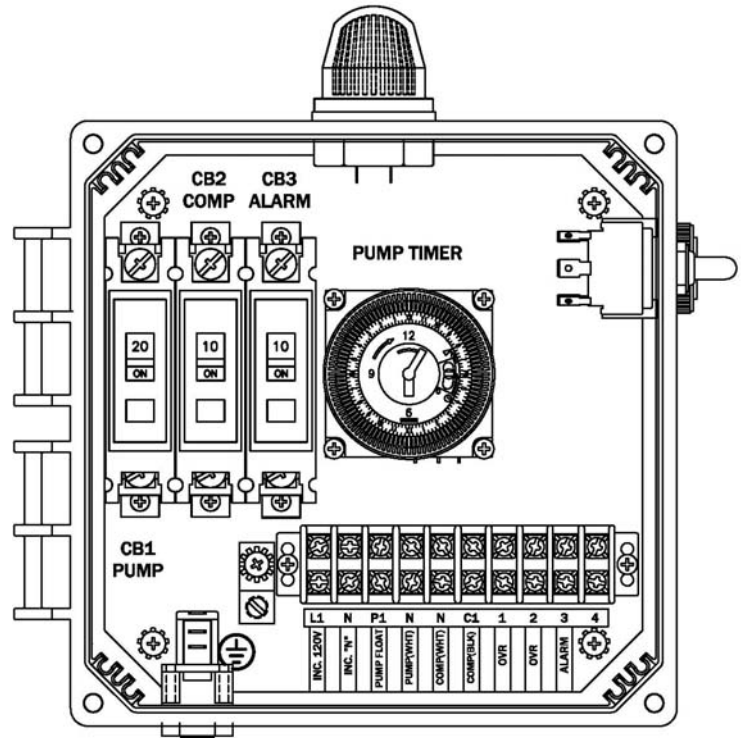

(50B109-CAV SHOWN)



Available Options

- **Externally Mounted Pump Test Switch**
- **Internally Mounted Air Pressure Switch**
- **Auto-Dialer**
- **Locking Stainless Steel Latch**
- **Repeat Cycle Timer Option**
- **Mercury or Mechanical Float Switches for the Pump and High Water Alarm Circuits**

Note: Consult the factory for other available options. Also, some options may require an increase in the enclosure size.



CONTROL PANEL

“50B109-CAV” Model Aerobic Control Panel

Panel Dimensions

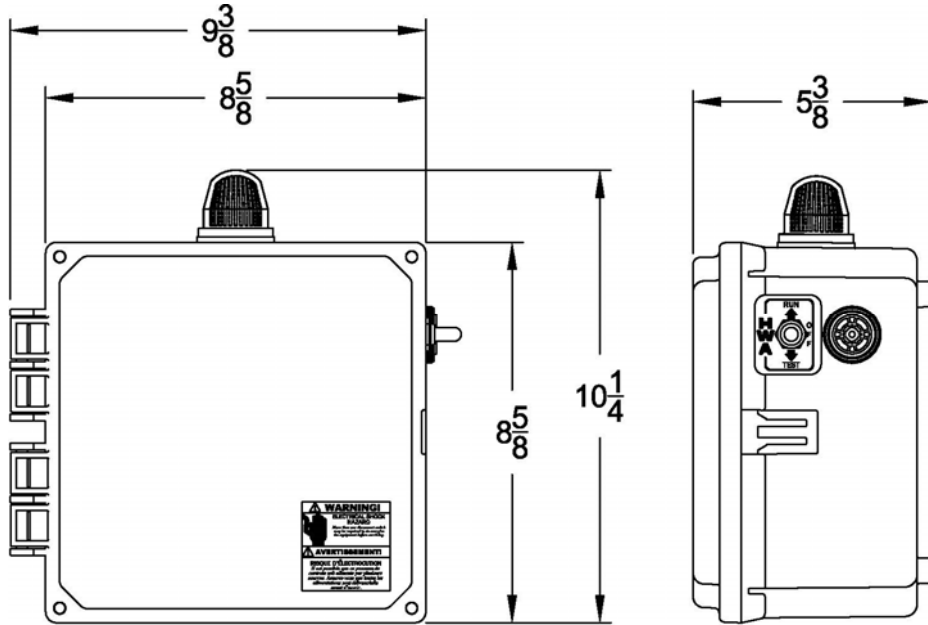

Wiring Schematic

