



CONTROL PANEL

“50B017-120D” Model Simplex Dosing Control Panel

Features & Benefits

- Circuit Breakers for Pump, & Control Circuits
- Repeat Cycle Timer
- Large & Easy to Access Terminal Block
- Usable with 115V Power
- Externally Mounted Run/Mute/Test Switch w/UV resistant sealing boot
- Externally Mounted Audible Alarm
- Rugged UV resistant Externally Mounted Alarm Light
- Durable Weather Resistant Hinged Poly Enclosure
- Pump Hand-Off-Auto Switch
- Definite Purpose Motor Contactor
- Ground Lug
- Easily Replaceable Components
- Nema 4x Rating
- Color Coded Internal Wiring
- Built and Labeled to UL 508A Standard
- Provided with Wiring Schematic and Detailed Connection Diagram for Installer
- Mounting Feet for Enclosure

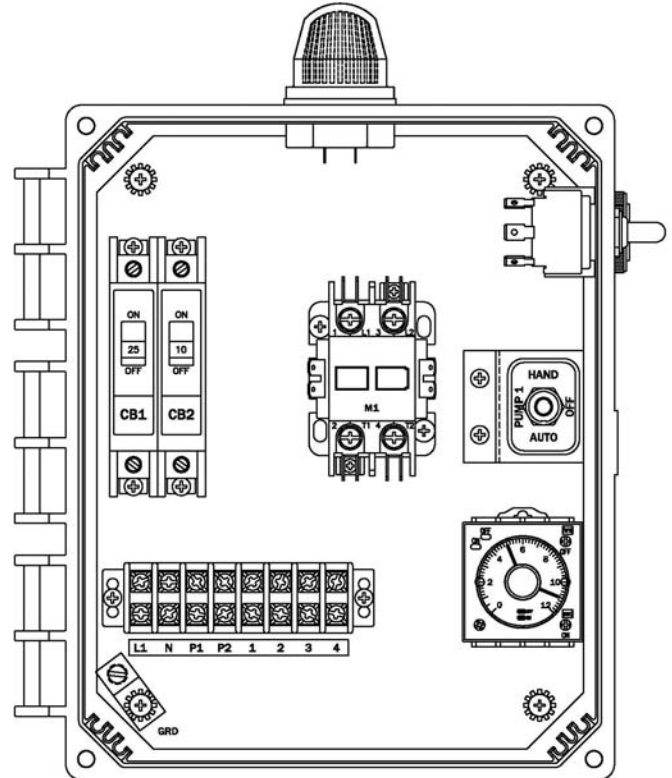

(50B017-120D Shown)



Available Options

- Auto-Dialer
- Locking Stainless Steel Latch
- Timer Override Float
- Auxiliary Alarm Contacts
- Elapsed Timer Meters
- Event or Cycle Counters
- Mercury or Mechanical Float Switches for the Pump and High Water Alarm Circuits

Note: Consult the factory for other available options. Also, some options may require an increase in the enclosure size.



CONTROL PANEL

“50B017-120D” Model Simplex Dosing Control Panel

Panel Dimensions

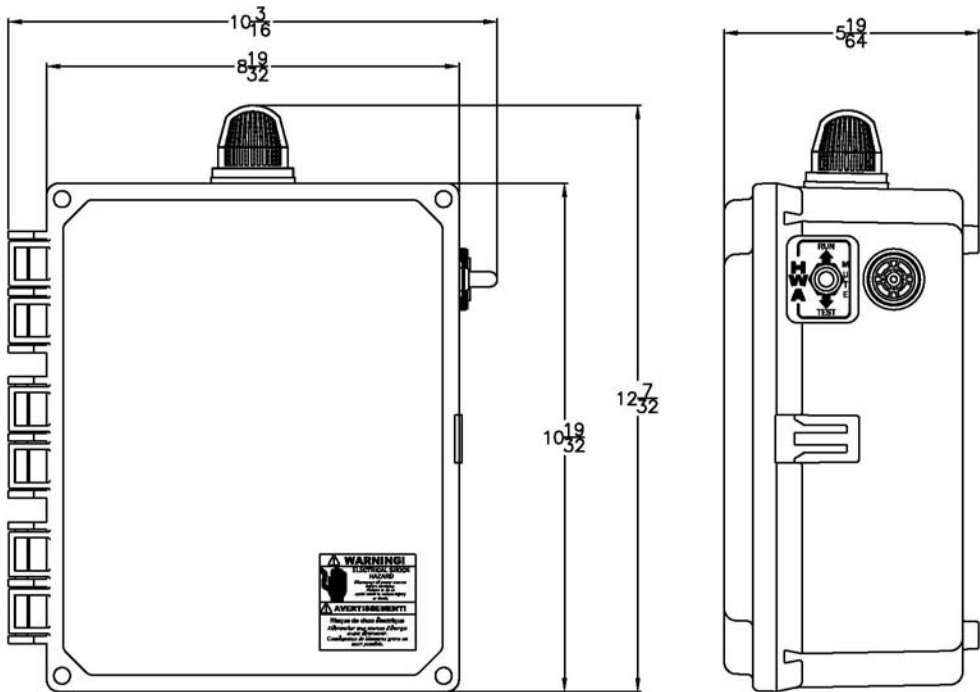

Wiring Schematic

