



CONTROL PANEL

“50B016-HWA88” Model Control Panel

Features & Benefits

- Circuit Breakers for Pump, & Alarm Circuits
- Easy to Access Terminal Block
- Externally Mounted Run/Mute/Test Switch w/UV resistant sealing boot
- Externally Mounted Audible Alarm
- Rugged UV resistant Externally Mounted Alarm Light
- Durable Weather Resistant Hinged Poly Enclosure
- Ground Lug
- Easily Replaceable Components
- Nema 4x Rating
- Color Coded Internal Wiring
- Built and Labeled to UL 508A Standard
- Provided with Wiring Schematic and Detailed Connection Diagram for Installer
- Mounting Feet for Enclosure

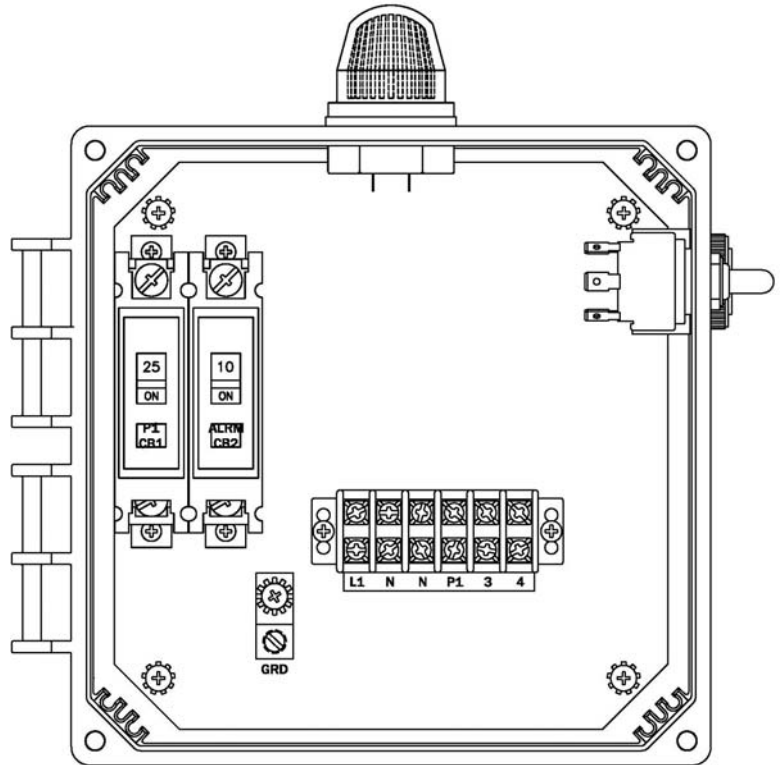

(50B016- HWA88 Shown)

Available Options

- Externally Mounted Pump Test Switch
- Separate Power Sources for Pump and Alarm Circuits
- Locking Stainless Steel Latch
- 230 Volt 1 Phase Version
- Mercury or Mechanical Float Switches for the Pump and High Water Alarm Circuits



Note: Consult the factory for other available options. Also some options may require an increase in the enclosure size.

“50B016-HWA88” Model Control Panel

Panel Dimensions

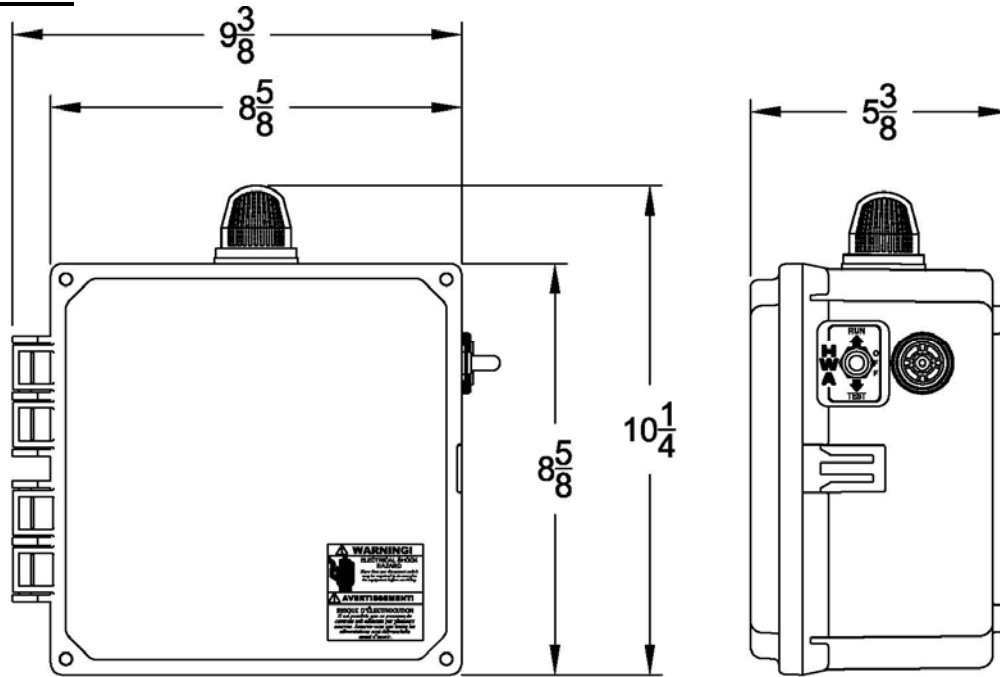

Wiring Schematic

