



# CONTROL PANEL

## “50B009-RW-T-1L” Model Aerobic Control Panel

### Features & Benefits

- Circuit Breakers for Pump, Compressor & Alarm Circuits
- 24 Hr Timer w/15 minute intervals
- 6A thermal breaker for compressor circuit
- Large & Easy to Access Terminal Block
- Externally Mounted Run/Mute/Test Switch w/UV resistant sealing boot
- Externally Mounted Audible Alarms
- Rugged UV resistant Externally Mounted Alarm Lights
- Separate Air Loss Alarm Circuit
- Externally or Internally Mounted Air Pressure Switch
- Durable Weather Resistant Hinged Poly Enclosure
- Silk Screen Back Panel
- Ground Lug
- Easily Replaceable Components
- Nema 4x Rating
- Color Coded Internal Wiring
- Built and Labeled to UL 508A Standard
- Provided with Wiring Schematic and Detailed Connection Diagram for Installer
- Mounting Feet for Enclosure

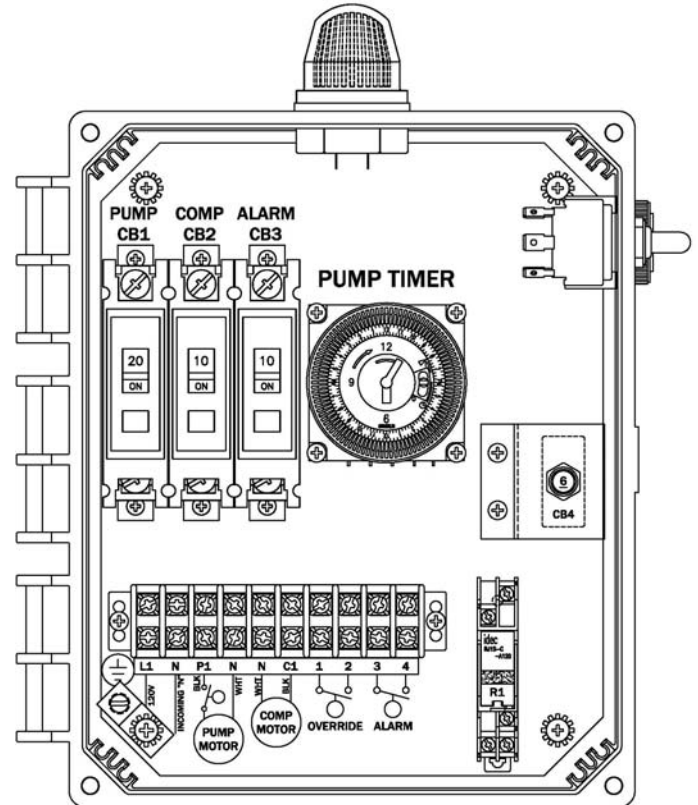

(50B009-RW-T-1L Shown)

### Available Options

- Externally Mounted Pump Test Switch
- Auto-Dialer
- Locking Stainless Steel Latch
- Repeat Cycle Timer Option
- Mercury or Mechanical Float Switches for the Pump and High Water Alarm Circuits



Note: Consult the factory for other available options. Also, some options may require an increase in the enclosure size.



# CONTROL PANEL

## “50B009-RW-T-1L” Model Aerobic Control Panel

### Panel Dimensions

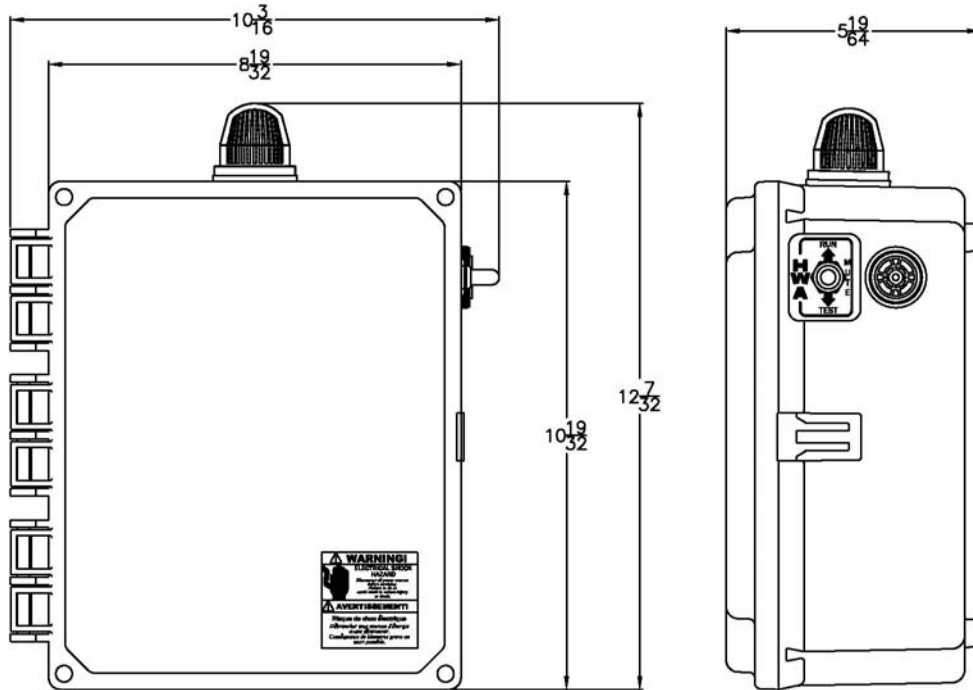

### Wiring Schematic

