



CONTROL PANEL

“50A808” Simplex 120V 1 Phase Control Panel

Features & Benefits

- Circuit Breaker for Pump Circuit
- Circuit Breaker for control and alarms
- Separate power circuit for control and alarms
- IEC Contactor
- Easy to Access Terminal Block
- Usable with 120VAC
- Alarm Silence Illuminated Push Switch
- Externally Mounted Audible Alarm
- Pump Hand-Off-Auto Switch
- Low-level Alarm & Redundant cut-off
- External Alarm Light
- 120VAC remote-alarm output
- Digital Dose Timers
- Digital Elapsed Time Meter & Cycle Counter
- Ground Lugs
- Color Coded Internal Wiring
- Rugged Weather Resistant Hinged
- Poly Enclosure w/Sst Latch
- Built and Labeled to UL 508A
Standard w/Nema 4x Rating
- Provided with Wiring Schematic and Detailed Connection Diagram for Installer
- Mounting Feet for Enclosure

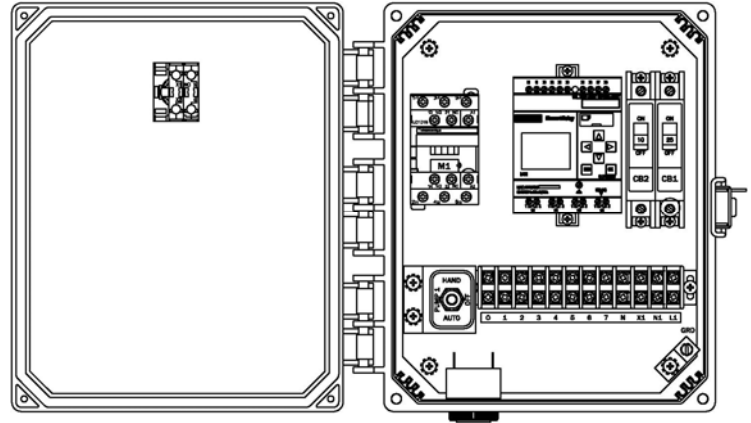

(Standard 50A808 Shown)



Available Options(*)

- Auxiliary Dry Alarm Contacts
- Anti-condensation heater

*Note: Consult the factory for other available options. Also some options may require an increase in the enclosure size.



CONTROL PANEL

“50A808” Simplex 120V 1 Phase Control Panel

Panel Dimensions

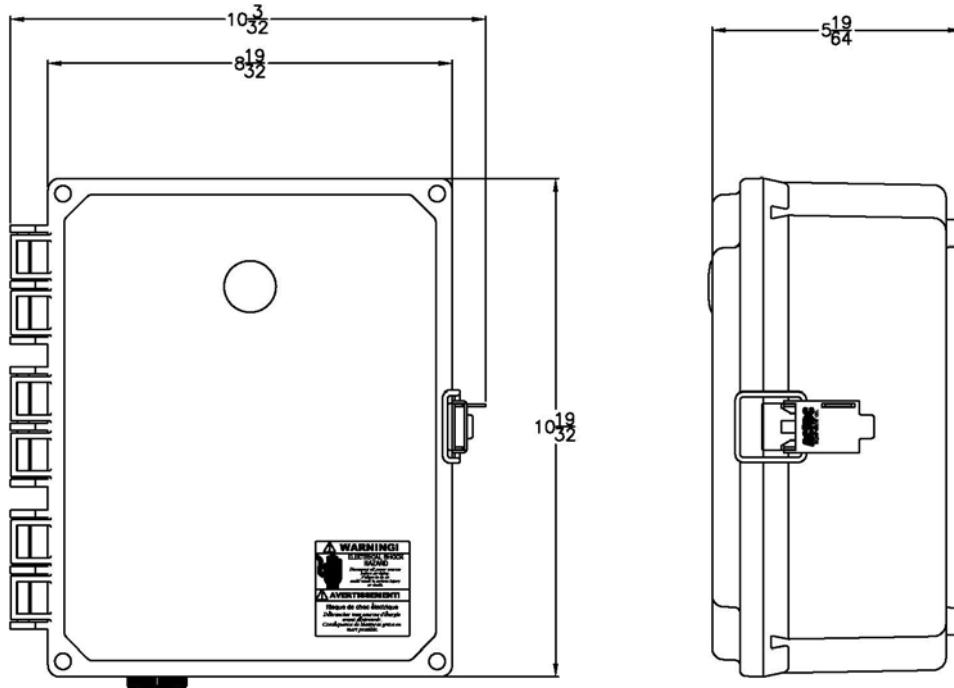

Panel Schematic

