



CONTROL PANEL

“50A754-C6-E7011” Model Duplex 230V 1 PH Grinder

Features & Benefits

- Circuit Breakers for Pump Circuits
- IEC Motor Contactor
- Easy to Access Terminal Block
- Alarm Silence & On-Off-Test Switches
- Externally Mounted Audible Alarm
- Pump Hand-Off-Auto Switches
- Pump Running Lights
- Alternating Relay for Reversible Pump
- Large External Alarm Light
- Fuse Protected Control & Alarm Circuits
- Ground Lugs
- Color Coded Internal Wiring
- Rugged Weather Resistant Hinged Enclosure w/Sst Latches
- Built and Labeled to UL 508A Standard w/Nema 4x Rating
- Provided with Wiring Schematic and Detailed Connection Diagram for Installer
- Seal Leak Indicator Light

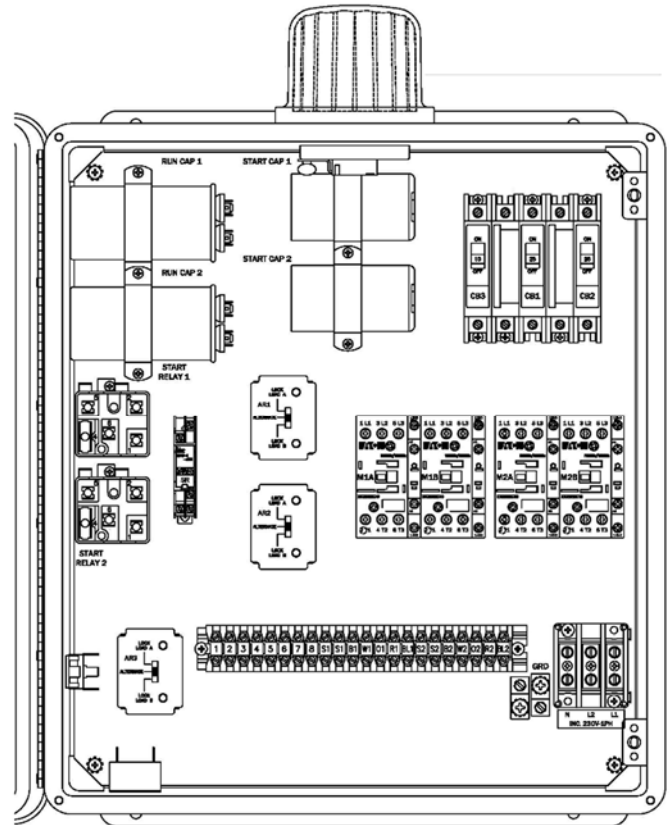

(Standard 50A754-C6-E7011 Model Shown)



*Note: Consult the factory for other available options. Also some options may require an increase in the enclosure size.



CONTROL PANEL

“50A754-C6-E7011” Model Duplex 230V 1 PH Grinder

Panel Dimensions

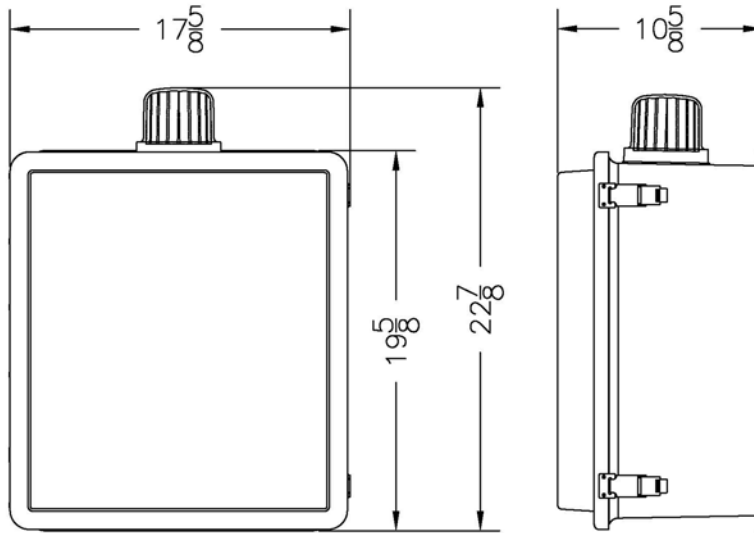

Panel Schematic

