



# CONTROL PANEL

## “50A516” Model Duplex Dual Voltage 3 Phase Control Panel

### Features & Benefits

- Manual Motor Protectors for Pumps
- Control Circuit Breaker
- IEC Motor Contactors
- Easy to Access Terminal Block
- Usable with 208/230 or 460VAC
- Externally Mounted Test/Normal/Silence Switch  
w/UV resistant sealing boot
- Externally Mounted Audible Alarm
- Pump Hand-Off-Auto Switches
- Pump Running Lights
- Transformer w/Primary & Secondary Fuse Protection
- Large External Alarm Light
- Separate Control & Alarm Fuses
- Ground Lugs
- Color Coded Internal Wiring
- Rugged Weather Resistant Hinged Enclosure w/Sst Latches
- Built and Labeled to UL 508A Standard w/Nema 4x Rating
- Provided with Wiring Schematic and Detailed Connection Diagram for Installer

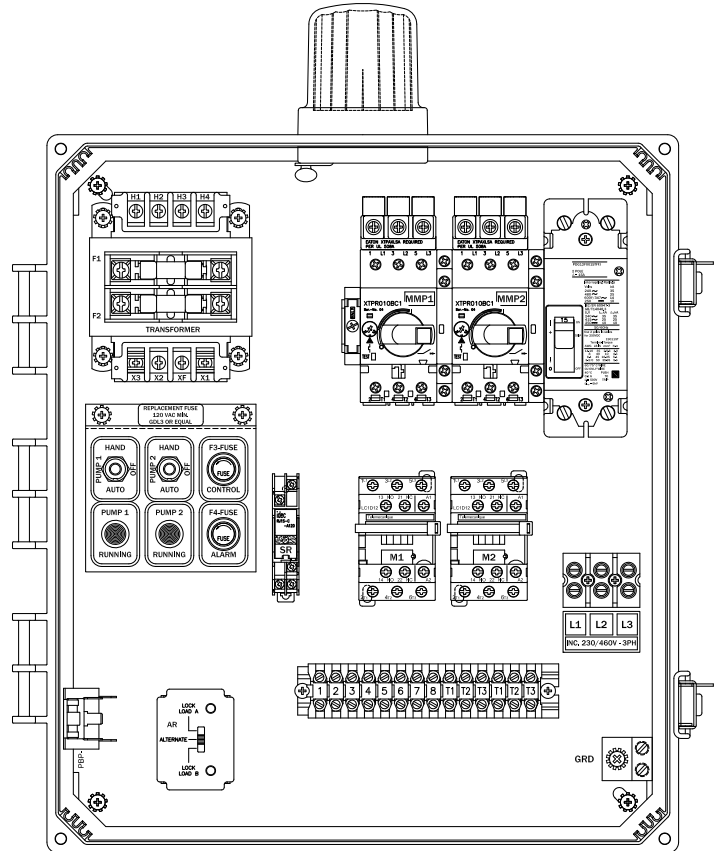

(Standard 50A516 Model Shown)

### Available Options(\*)

- Flasher
- Mercury or Mechanical Float Switches for the Pumps and High Water Alarm Circuits



\*Note: Consult the factory for other available options. Also, some options may require an increase in the enclosure size.

**“50A516” Model Duplex Dual Voltage 3 Phase Control Panel**

**Panel Dimensions**

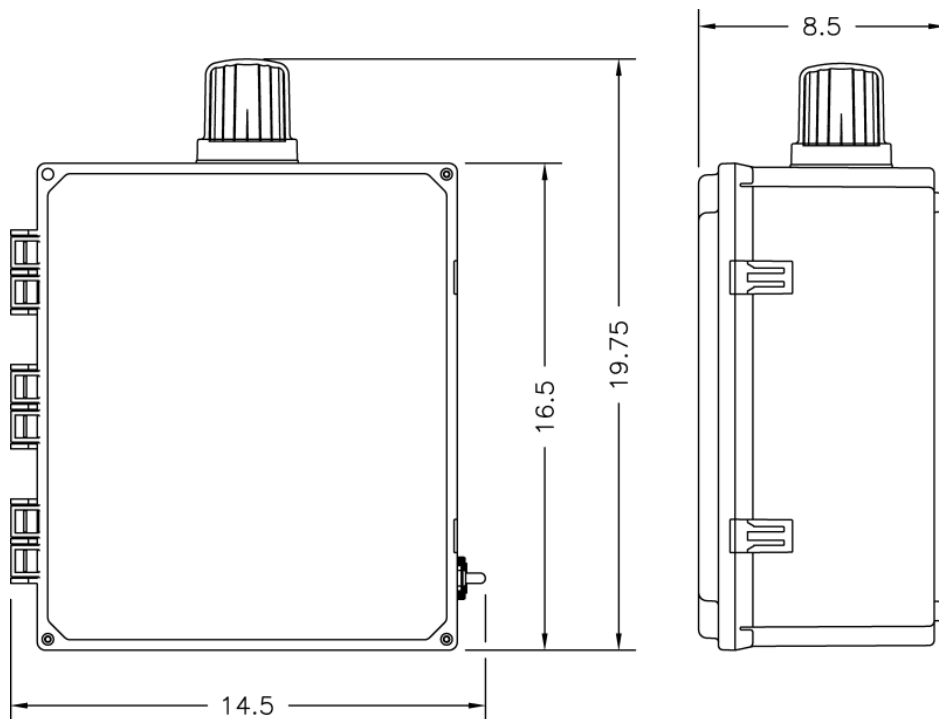

**Panel Schematic**

