



CONTROL PANEL

“Bio Duplex” Model 230V 1 Phase Control Panel

Features & Benefits

- Circuit Breakers for Pump Circuits
- Circuit Breaker for Control Circuit
- Definite Purpose Contactor
- Easy to Access Terminal Block
- Externally Mounted Audible Alarm
- Pump Hand-Off-Auto Switch
- External Alarm Light
- Ground Lugs
- Color Coded Internal Wiring
- Rugged Weather Resistant Hinged Poly Enclosure w/Sst Latch
- Built and Labeled to UL 508A Standard w/Nema 4x Rating
- Provided with Wiring Schematic and Detailed Connection Diagram for Installer
- Mounting Feet for Enclosure
- Event or Cycle Counter

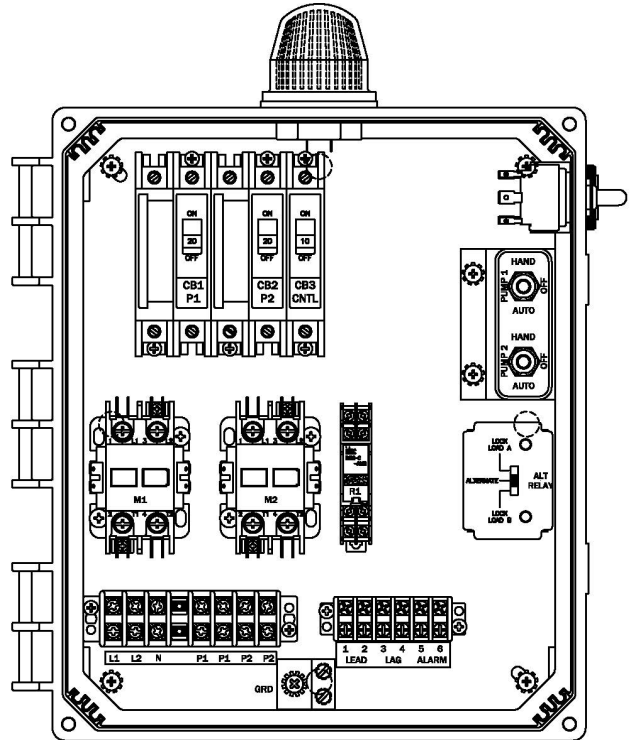

(50A502B Shown)

Available Options(*)

- Fiberglass Enclosure
- IEC Motor Contactor
- Flasher
- Dead Front Inner Door
- Auxiliary Alarm Contacts
- Elapsed Time Meter
- Event or Cycle Counter
- Mercury or Mechanical Float Switches for the Pumps and High Water Alarm Circuits



*Note: Consult the factory for other available options. Also some options may require an increase in the enclosure size.



CONTROL PANEL

“Bio Duplex” Model 230V 1 Phase Control Panel

Panel Dimensions

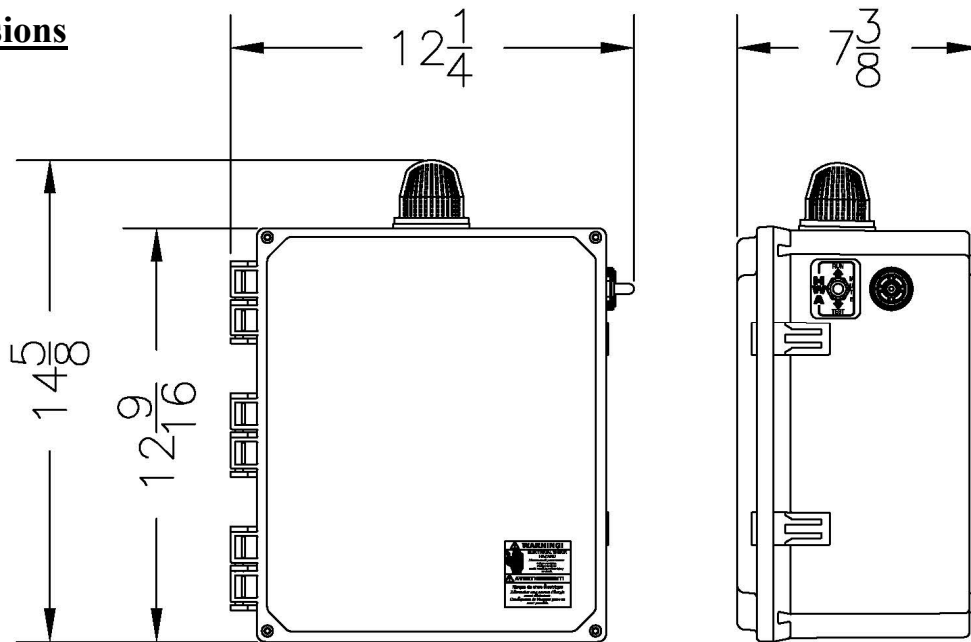

Panel Schematic

