



CONTROL PANEL

“50A016” Model Simplex Dual Voltage 3 Phase Control Panel

Features & Benefits

- Manual Motor Protector for Pump
- Control Circuit Breaker
- IEC Motor Contactor
- Easy to Access Terminal Block
- Usable with 208/230 or 460VAC
- Externally Mounted Test/Normal/Silence Switch w/UV resistant sealing boot
- Externally Mounted Audible Alarm
- Pump Hand-Off-Auto Switches
- Pump Running Lights
- Transformer w/Primary & Secondary Fuse Protection
- Large External Alarm Light
- Separate Control & Alarm Fuses
- Ground Lugs
- Color Coded Internal Wiring
- Rugged Weather Resistant Hinged Enclosure w/Sst Latches
- Built and Labeled to UL 508A Standard w/Nema 4x Rating
- Provided with Wiring Schematic and Detailed Connection Diagram for Installer

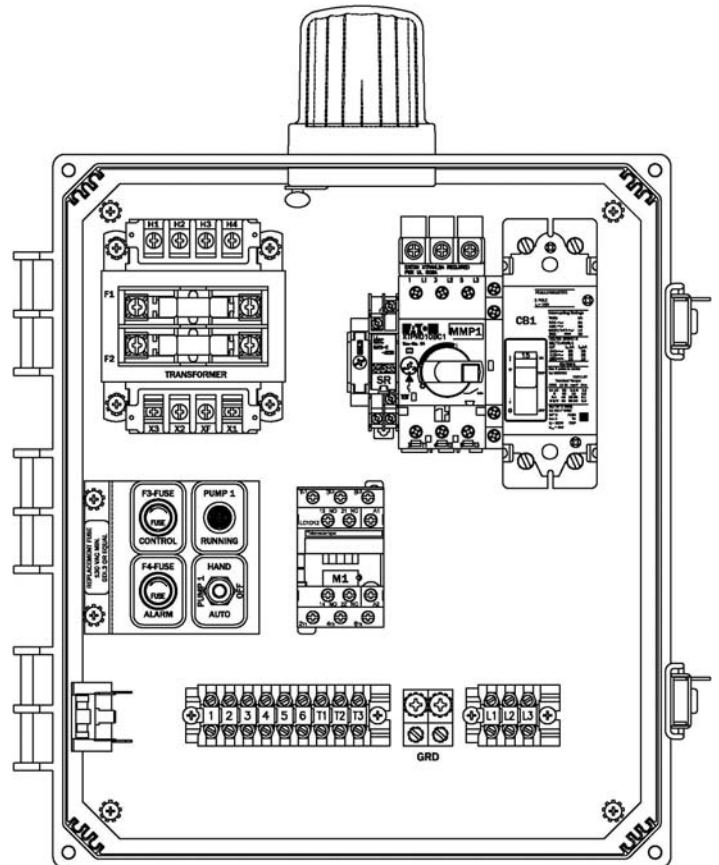

(Standard 50A016 Model Shown)

Available Options(*)

- Flasher
- Mercury or Mechanical Float Switches for the Pump and High Water Alarm Circuits



*Note: Consult the factory for other available options. Also some options may require an increase in the enclosure size.

“50A016” Model Simplex Dual Voltage 3 Phase Control Panel

Panel Dimensions

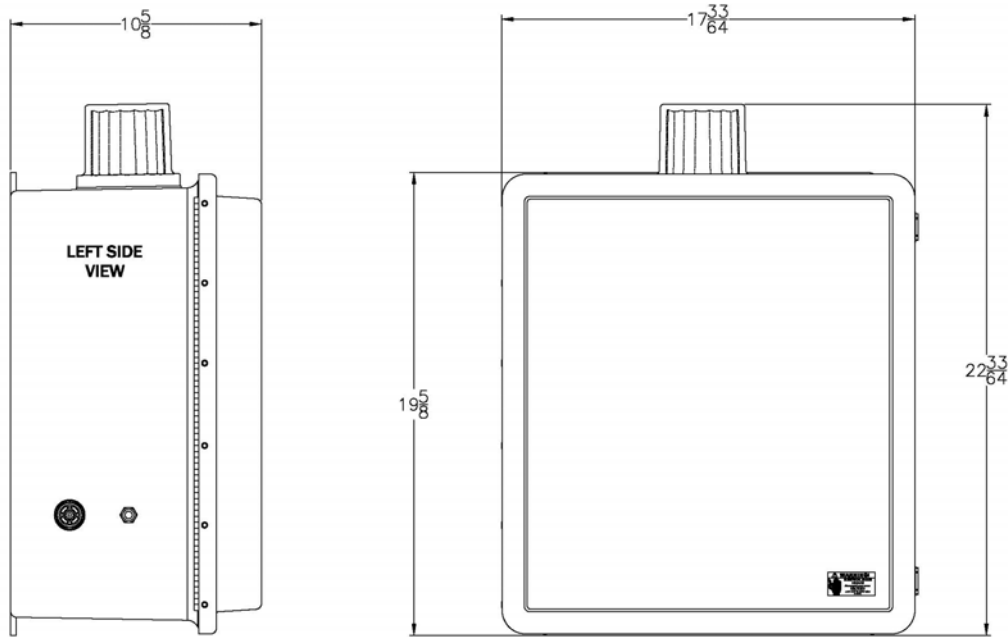

Panel Schematic

