



CONTROL PANEL

“50A008” Model Simplex 3 Phase Control Panel

Features & Benefits

- Circuit Breakers for Pump Circuit
- Circuit Breaker for Controls & Alarm
- IEC Motor Contactor & Overload
- Easy to Access Terminal Block
- Usable with 460 VAC
- Externally Mounted Test/Normal/Silence Switch w/UV resistant sealing boot
- Externally Mounted Audible Alarm
- Pump Hand-Off-Auto Switch
- Pump Running Light
- Transformer w/Primary & Secondary Fuse Protection
- Large External Alarm Light
- Separate Control & Alarm Fuses
- Ground Lugs
- Color Coded Internal Wiring
- Rugged Weather Resistant Hinged Poly Enclosure w/Sst Latches
- Built and Labeled to UL 508A Standard w/Nema 4x Rating
- Provided with Wiring Schematic and Detailed Connection Diagram for Installer
- Mounting Feet for Enclosure

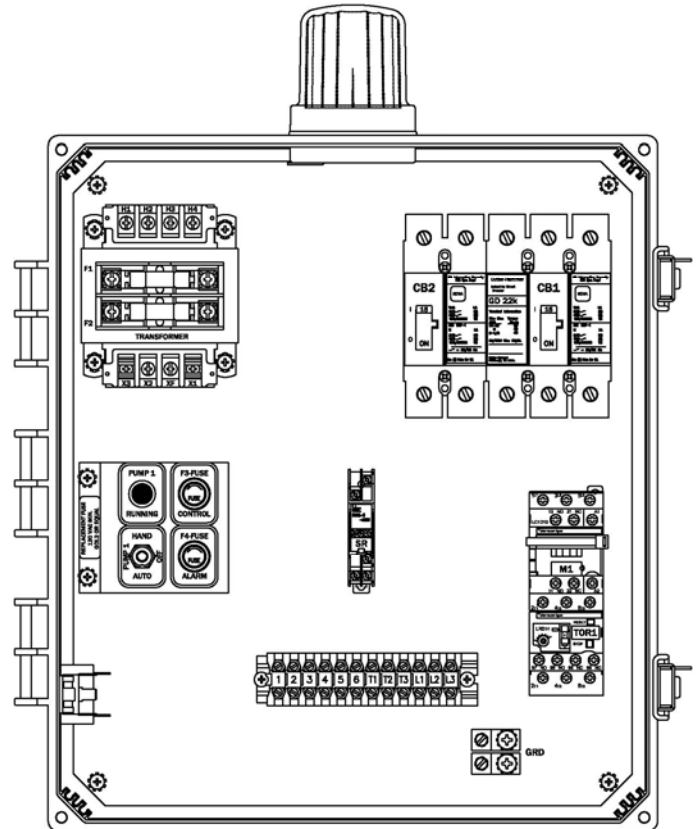

(Standard 50A008 Shown)



Available Options(*)

- Fiberglass Enclosure
- Flasher
- Dead Front Inner Door
- Auxiliary Alarm Contacts
- Mercury or Mechanical Float Switches for the Pumps and High Water Alarm Circuits

*Note: Consult the factory for other available options. Also some options may require an increase in the enclosure size.



CONTROL PANEL

“50A008” Model Simplex 3 Phase Control Panel

Panel Dimensions

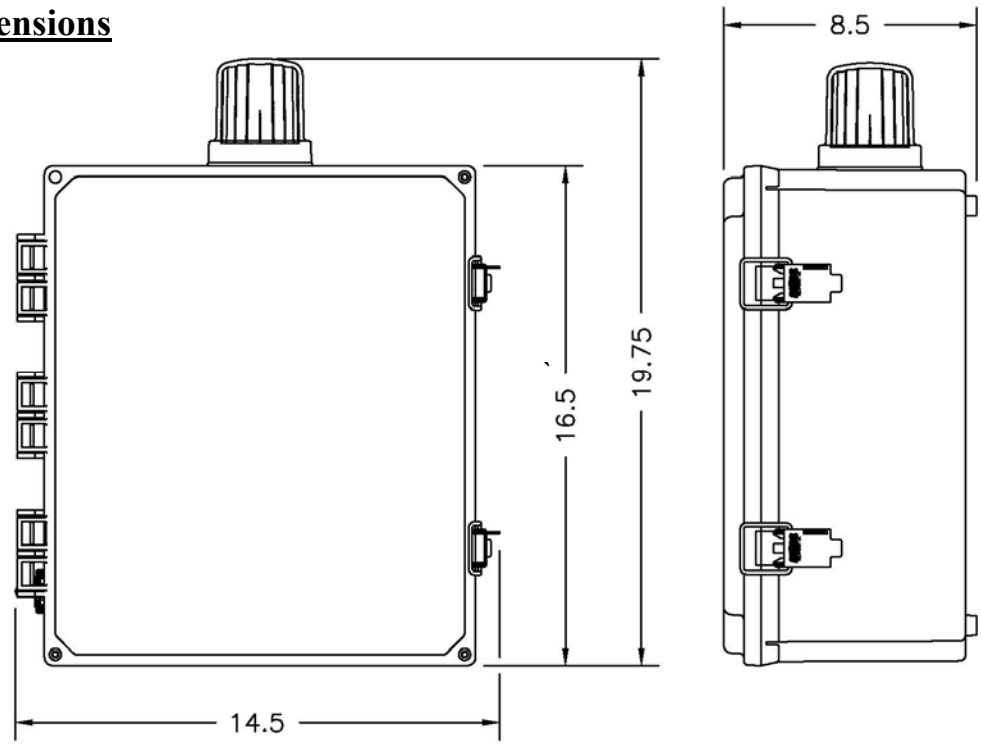

Panel Schematic

