



CONTROL PANEL

“50A006B” Basic Model Simplex 115/230V 1 Phase Control Panel

Features & Benefits

- Circuit Breaker for Pump Circuit
- Definite Purpose Contactor
- Easy to Access Terminal Block
- Usable with 115 or 230 VAC
- Alarm Run-Mute-Test Switch
- Externally Mounted Audible Alarm
- Pump Hand-Off-Auto Switch
- External Alarm Light
- Control Circuit Breaker
- Ground Lug
- Color Coded Internal Wiring
- Rugged Weather Resistant Hinged Poly Enclosure
- Built and Labeled to UL 508A
Standard w/Nema 4x Rating
- Provided with Wiring Schematic and Detailed
Connection Diagram for Installer
- Mounting Feet for Enclosure

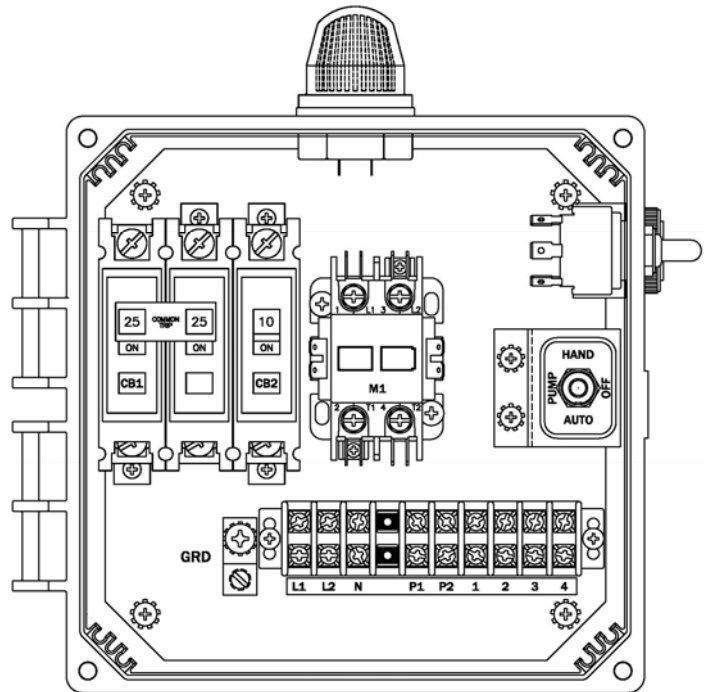

(Standard 50A006B Shown)



Available Options(*)

- Customer Specific Float Configuration
- IEC Motor Contactor
- Flasher
- 7 Conductor Cable Terminal Block Configuration
- Auxiliary Alarm Contacts
- Elapsed Time Meter
- Event or Cycle Counter
- Mercury or Mechanical Float Switches for the Pump and High Water Alarm Circuits

*Note: Consult the factory for other available options. Also, some options may require an increase in the enclosure size.



CONTROL PANEL

“50A006B” Basic Model Simplex 115/230V 1 Phase Control Panel

Panel Dimensions

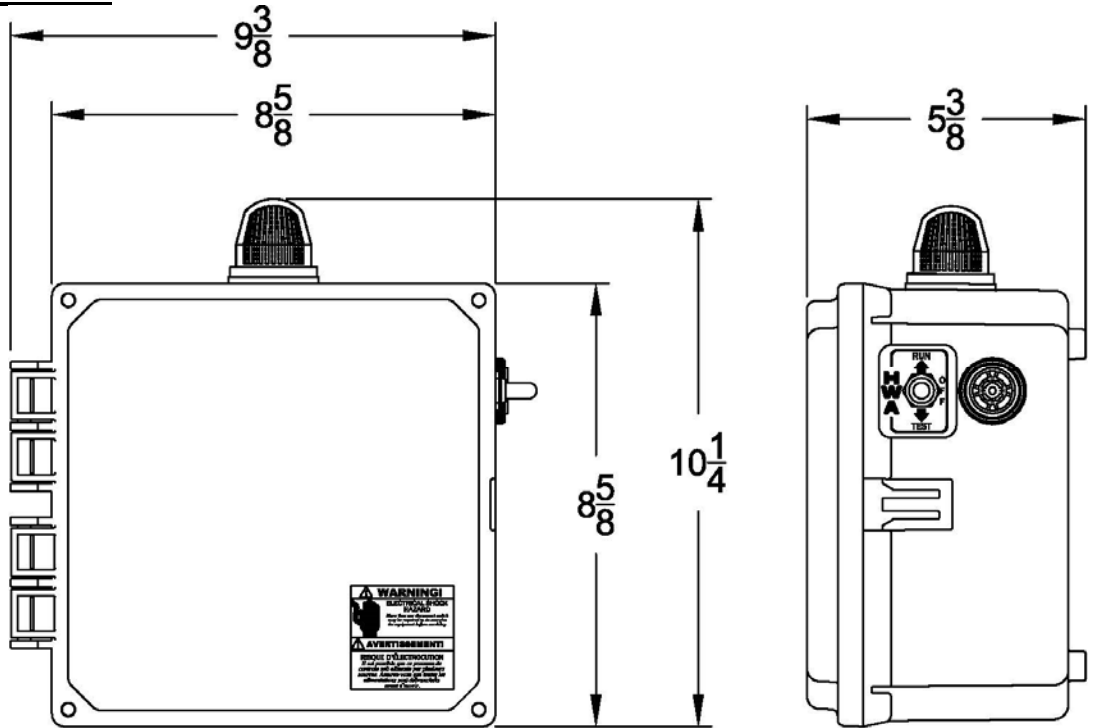

Panel Schematic

