

**Observer 300 Indoor Alarm**

<b>⚠ WARNING</b>	<b>ELECTRICAL SHOCK HAZARD</b> Disconnect power before installing or servicing this product. A qualified service person must install and service this product according to applicable electrical and plumbing codes.	<b>⚠ WARNING</b>	<b>EXPLOSION OR FIRE HAZARD</b> Do not use this product with flammable liquids. Do not install in hazardous locations as defined by National Electrical Code, ANSI/NFPA 70.
------------------	---	------------------	--

1. Observe National Electric Code, ANSI/NFPA 70, when installing this unit to prevent moisture buildup. SPI is not responsible for damage or injury resulting from improper installation procedure.
2. Turn off power.
3. On the back of the enclosure, there is a slotted keyhole for mounting with a screw. Install a screw in the wall and slide the keyhole over the screw head. Use the mounting foot at the bottom to secure the alarm in place.
4. Strip the insulation from the end of a float switch cord. See figure 1 for the recommended lengths.
5. Press the levers on the output terminal to open the connectors for the alarm float switch. At the black connector, inset the exposed end of the black float switch wire. Release the connector lever. Repeat the process for the red connector and white float switch lead.
6. Plug the power cord into a 120 VAC outlet. The green power light will switch on.
7. Test the alarm by tilting the alarm float switch. The buzzer and alarm light should switch on. If it does not, try the test button. If the alarm is still not functioning, contact your sales representative or SPI.

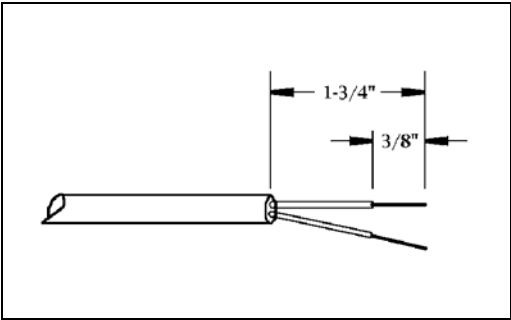

Figure 1: Recommended strip lengths

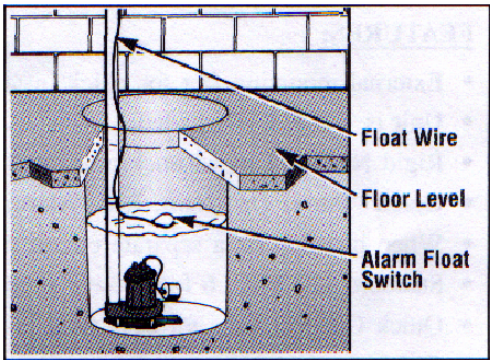

Figure 2: General tank setup



# ALARM SYSTEMS

## “Observer 300” Series Indoor Alarm

### Features & Benefits

- NEMA 1 Steel Enclosure
- Power “On” Indicating Light
- Alarm Condition Indicating Light
- Audible Horn rated 85db @ 10’
- Alarm Silence & Test Buttons
- Automatic Alarm Reset
- Quick Connect Block for Alarm Float
- Includes 15’ Mechanical Alarm Float & mounting tie strap
- 6’ Power Cord with 115 volt plug
- Two Year Limited Warranty
- Available in both High Water & Low Level Alarm versions



### Dimensions

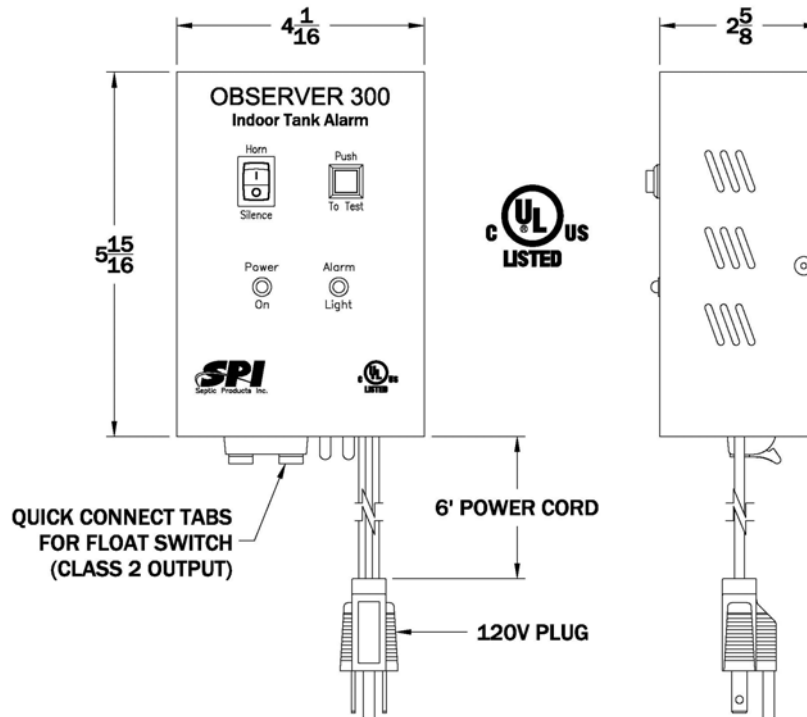

\*Note: Consult the factory for other available options.