

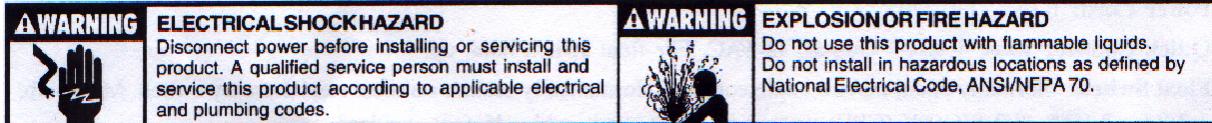

## “Observer 100” Series Pedestal Alarm



1. Observe National Electric Code, ANSI/NFPA 70, when installing this unit to prevent moisture buildup. SPI is not responsible for damage or injury resulting from improper installation procedure.
2. Turn off power.
3. Run two power supplies with independent breakers to the panel such that a fault in the pump circuit will not affect the power to the alarm circuit. Note that the alarm circuit is a 115 VAC only circuit. However, the pump circuit may be wired for 230 or 115 VAC depending on the model. Your panel will include a plug-in pump receptacle that is designed for the voltage you specify.
4. Remove the two screws that secure the cover and baseplate to the pedestal. With the screws removed, the cover and baseplate may be pulled off. Bury the pedestal at least 24” deep to ensure that it is properly secured.
5. Route power and float cords through the pedestal as required. Use standard plumbing fixtures and cord seals for through-wall junctions. For product endurance, the installer must ensure that humidity and septic gases cannot leak into the pedestal head. Cord grips and cord seals have been provided for junctions to the base plate.
6. If you will be using a remote alarm or second power supply, remove the plug from the second cord grip and route wires here. Wire power / remote alarm per terminal block diagrams. Consult terminal block diagrams for connection instructions.
7. Remove the circular rubber seal. Feed the pump, alarm float switch, and pump float switch cords through the opening.
8. Insert the rubber seal with cords positioned in the openings of the seal and washers. If you only need one float, use the included plugs to seal the unused cord position.
9. If you are using a “piggyback” pump float switch, plug the float switch into the pump power receptacle. The pump should then plug into the float switch. If the float switch is built into the pump, you may simply plug in the pump.
10. Install 9 volt battery for back-up alarm power using the provided connector on the outlet side.
11. Turn the power on and use the test switch to test the alarm. The buzzer and alarm light should turn on. Test the pump by lifting the float switch. The pump should switch on and switch off when the float is lowered.
12. Reassemble the pedestal head and re-secure the cover with the provided screws.

TIGHTENING TORQUE FOR TERMINAL BLOCK IS 9 in-lbs.

10A100

PAGE  
1

(USE WITH ONE 115V  
POWER SUPPLY)

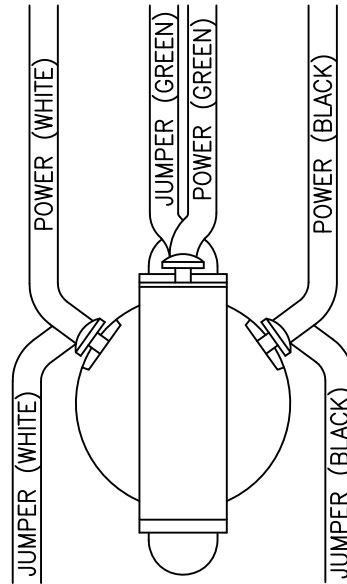
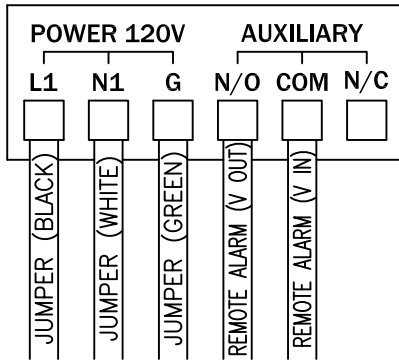
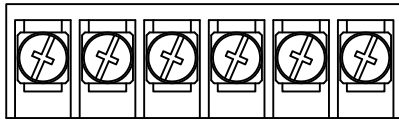

SPEAKER TERMINALS  
(ALARM FLOAT  
CONNECTION)

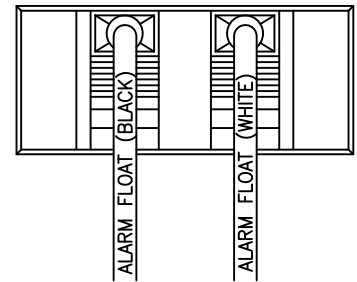

\*OR\*

(USE WITH TWO 115V  
POWER SUPPLIES)

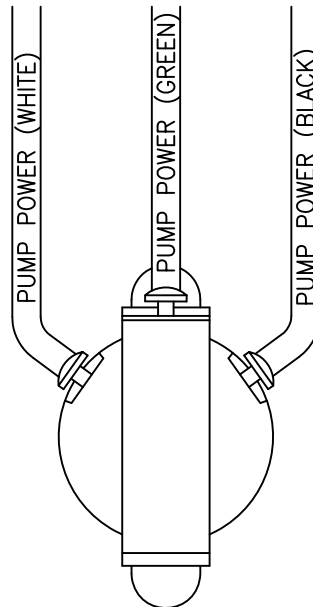
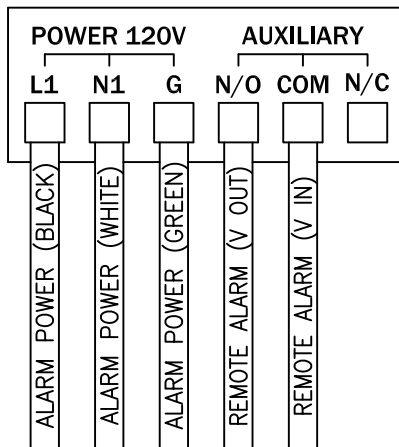
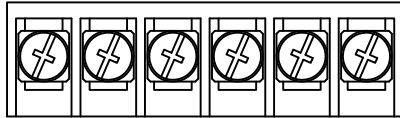

SPEAKER TERMINALS  
(ALARM FLOAT  
CONNECTION)

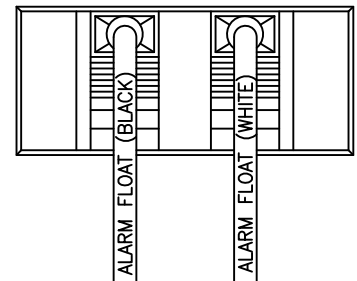

ALL INFORMATION CONTAINED IN THIS DRAWING IS  
CONFIDENTIAL AND PROPRIETARY TO SEPTIC PRODUCTS, INC.

**SPI**  
SEPTIC PRODUCTS INC

CHANGES		TOLERANCES		DRAWN BY		DATE		
F		DECIMALS		C. BARRICK		06/30/17	CONNECTION DIAGRAM	
E		.XXX = ±.005		MATERIAL SPECIFICATION:				
D		.XX = ±.010						
C		FRACTIONAL		AS NOTED			SCALE:	
B		X/X = ±.1/64					PART NO.	
A		ANGLES					FULL	10A100
		X° = ±1/2°						