

TIGHTENING TORQUE FOR TERMINAL BLOCK IS 9 in-lbs.

MODEL NO.

120DT-1CAL

PAGE

1

CONNECTION DIAGRAM

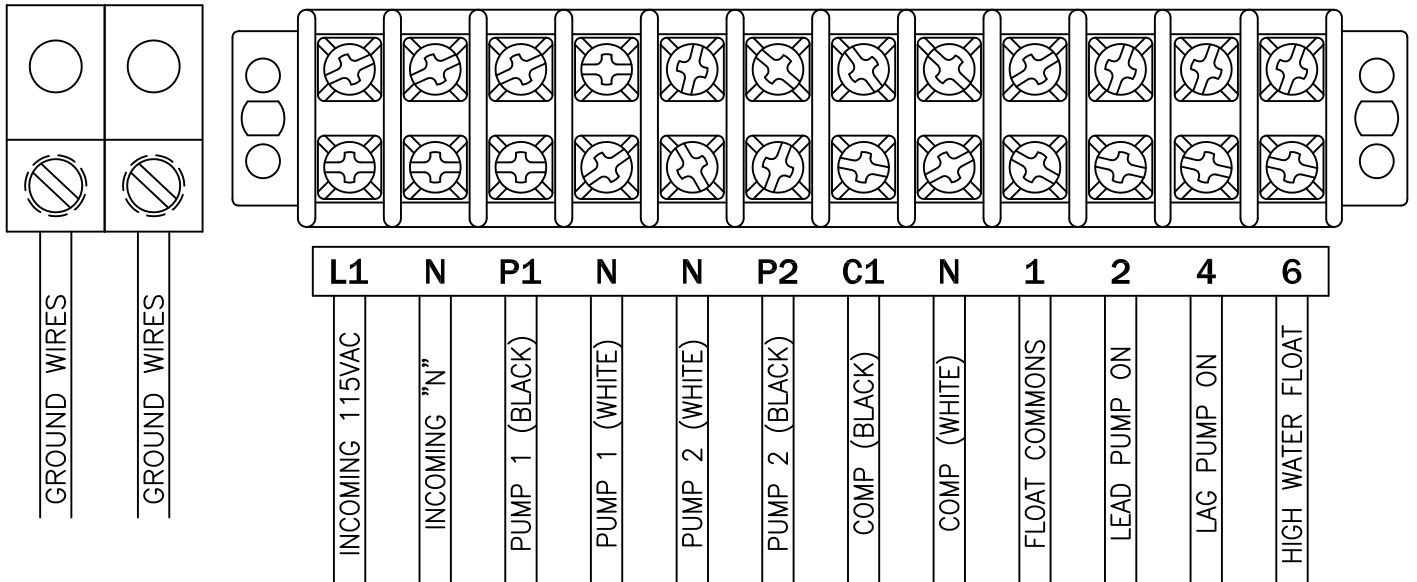

ALL INFORMATION CONTAINED IN THIS DRAWING IS
CONFIDENTIAL AND PROPRIETARY TO SEPTIC PRODUCTS INC.



CHANGES	TOLERANCES	DRAWN BY	DATE	POWER CONNECTION DUPLIX TIMED
F	DECIMALS .XXX = ±.005 .XX = ±.010 FRACTIONAL X/X = ±.1/64 ANGLES X° = ±1/2°	C. BARRICK	3/18/2011	
E		MATERIAL SPECIFICATION:		
D		AS NOTED		
C		SCALE:	PART NO.	
B		FULL	50B021	
A				

POWER CIRCUIT
115V - 1PH

NOTE: PUMP MOTORS MUST HAVE
INTERNAL OVERLOAD PROTECTION.

MODEL NO.
120DT-1CAL

PAGE
2

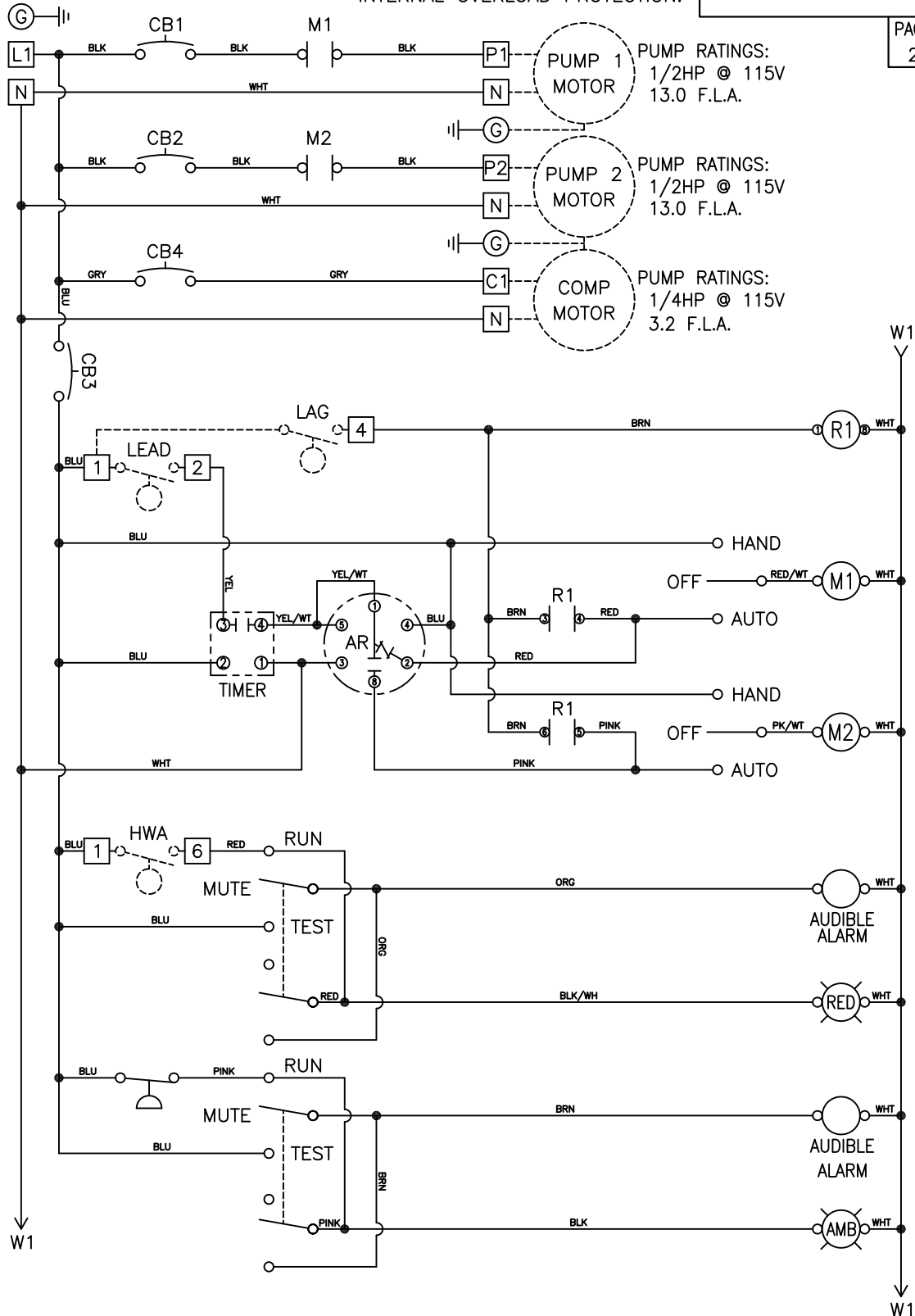

NOTES: MAIN PANEL DISCONNECT MUST BE PROVIDED BY INSTALLER.
DASHED LINES INDICATE ITEMS NOT CONTAINED IN THE PANEL.
FIELD WIRING MUST BE A MINIMUM OF 60°C COPPER WIRE. ALL
INFORMATION CONTAINED IN THIS DRAWING IS CONFIDENTIAL AND
PROPRIETARY TO SEPTIC PRODUCTS INC.



CHANGES	TOLERANCES	DRAWN BY	DATE
F	DECIMALS .XXX = ±.005 .XX = ±.010	C. BARRICK	4/24/18
E	FRACTIONAL X/X = ±.1/64 ANGLES X' = ±1/2'	MATERIAL SPECIFICATION:	
D		AS NOTED	
C			
B			
A			

SCHEMATIC, ELECTRICAL

SCALE: PART NO.
FULL 50B021